



Heyco-Flex™ VI Liquid Tight Conduit Fittings

Nickel-plated Brass Construction

Straight-Thru, NPT Hubs

TRADE SIZE	PART NO.	DESCRIPTION	PART DIMENSIONS									
			A Clearance Hole		B Max O.A. Length		C Thread Length		D Wrenching Nut Flat Size		E Wrenching Flat Size	
			in.	mm.	in.	mm.	in.	mm.	in.	mm.	in.	mm.
3/8	4028	HF6C 3/8	.874	22,2	1.38	35,0	.55	14,0	1.02	26,0	.95	24,0
1/2	4029	HF6C 1/2	.874	22,2	1.42	36,0	.55	14,0	1.14	29,0	1.06	27,0
3/4	4030	HF6C 3/4	1.040	26,4	1.46	37,0	.55	14,0	1.38	35,0	1.30	33,0
1	4031	HF6C 1	1.327	33,7	1.58	40,0	.63	16,0	1.77	45,0	1.65	42,0

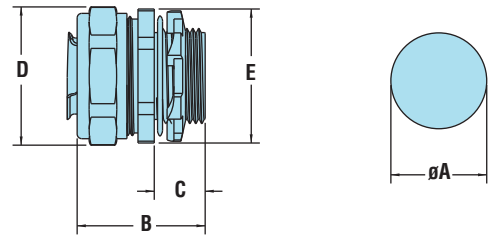

- Designed with an insulated throat to prevent wire damage during installation.
- Excellent corrosion resistance, strength, and durability.
- Connector is ideal for use with standard liquid-tight conduit to allow easy installation. IP 66/67 rated when installed with approved conduit.
- Approved for both exposed and concealed locations.
- Suitable for harsh industrial, food and beverage, petro-chemical, waste water, salt water, and other corrosive applications.
- Suitable for use in hazardous locations per NEC Articles 501 Class I Div. 2, Article 502 Class II Div. 1 & 2, Article 503 Class III Div. 1 & 2.
- Complies with UL Standard 360 File No. E18917; CSA C22.2 File No. 158897; and NEC Article 350.
- DFARS Compliant

90° Sweep, NPT Hubs

TRADE SIZE	PART NO.	DESCRIPTION	PART DIMENSIONS									
			A Clearance Hole		B Max O.A. Length		C Thread Length		D Wrenching Nut Flat Size		E Wrenching Flat Size	
			in.	mm.	in.	mm.	in.	mm.	in.	mm.	in.	mm.
3/8	4032	HF6C 3/8-90	.874	22,2	1.18	30,0	.55	14,0	1.02	26,0	.95	24,0
1/2	4033	HF6C 1/2-90	.874	22,2	1.38	32,0	.55	14,0	1.14	29,0	1.06	27,0
3/4	4034	HF6C 3/4-90	1.040	26,4	1.42	36,0	.55	14,0	1.38	35,0	1.30	33,0
1	4035	HF6C 1-90	1.327	33,7	1.93	49,0	.63	16,0	1.77	45,0	1.65	42,0

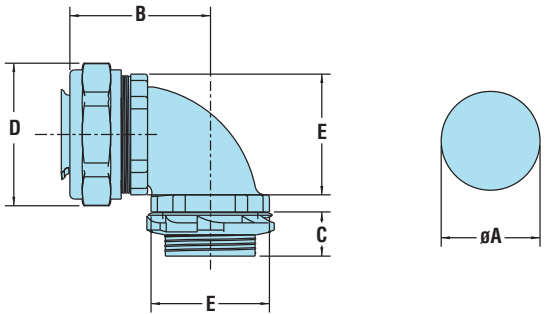

Material	Nickel Plated Brass with a PA6 clamping ring, galvanized steel ferrule and locknut and NBR rubber washer
Certifications	Certified by Underwriters' Laboratories for Compliance with both Canadian and U.S. requirements under File E234207
Temperature Range	-45°F (-45°C) to 221°F(105°C)

Quick Specs